



VARIABLES

DIAGRAM

Name	Type	Value
start	Bool	False
S1	Bool	True
S2	Bool	False
YA	Bool	False
state1	Bool	True
state2	Bool	False
state3	Bool	False
state4	Bool	False
reset	Bool	True
T0	Timer	▼

Add new variable Bool Submit





VARIABLES

DIAGRAM

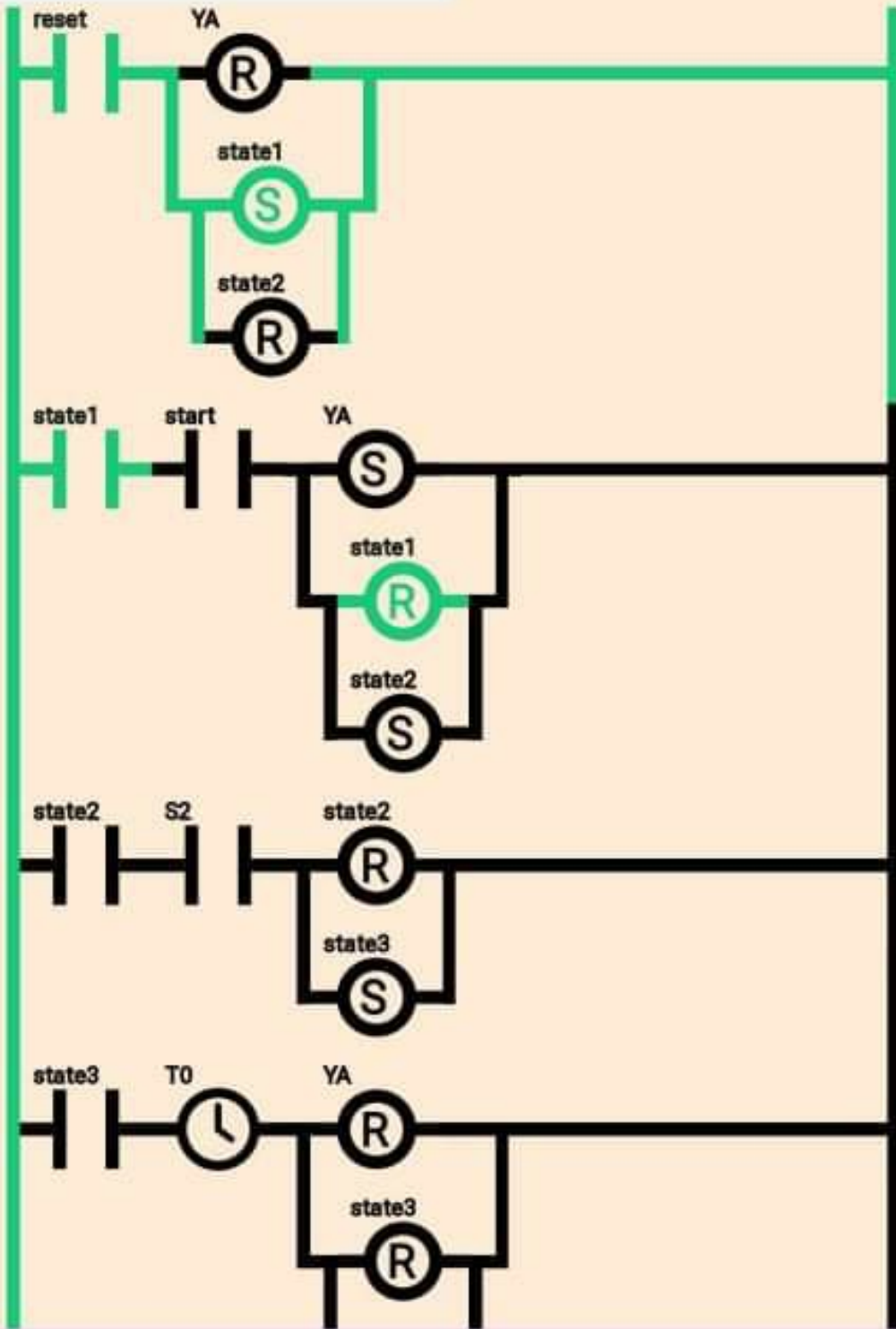

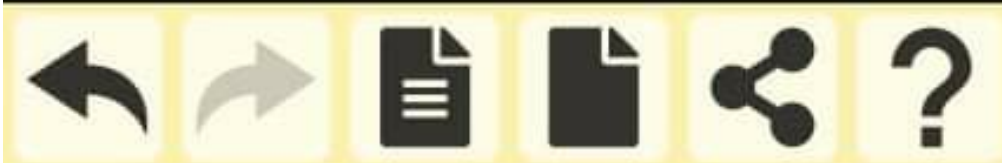

VARIABLES

DIAGRAM

Name	Type	Value
start	Bool	False
S1	Bool	True
S2	Bool	False
YA	Bool	False
state1	Bool	True
state2	Bool	False
state3	Bool	False
state4	Bool	False
reset	Bool	False
T0	Timer	▼

Add new variable

Bool



Submit





VARIABLES

DIAGRAM

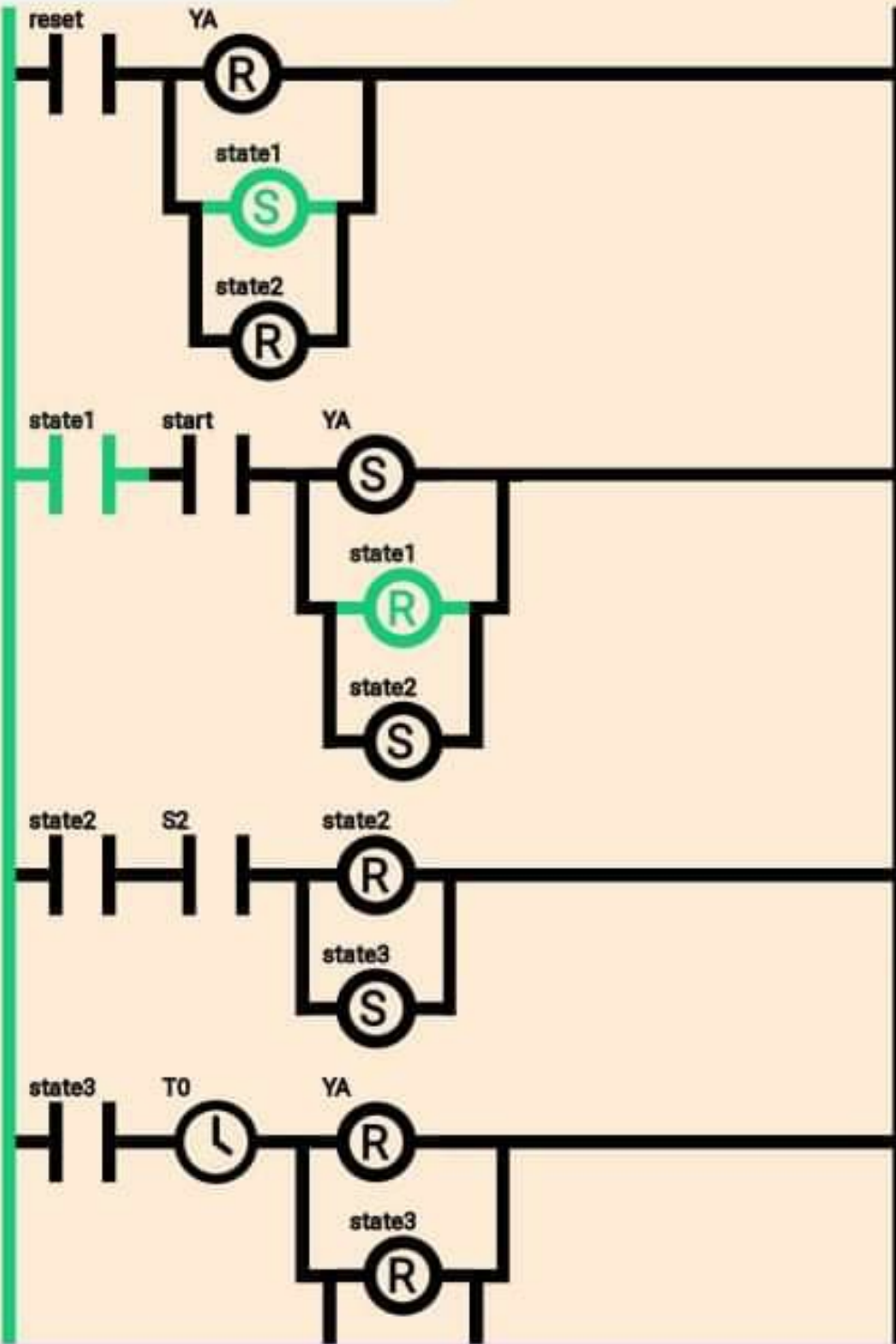



VARIABLES

DIAGRAM

Name	Type	Value
start	Bool	True
S1	Bool	True
S2	Bool	False
YA	Bool	True
state1	Bool	False
state2	Bool	True
state3	Bool	False
state4	Bool	False
reset	Bool	False
T0	Timer	▼

Add new variable Bool Submit





VARIABLES

DIAGRAM

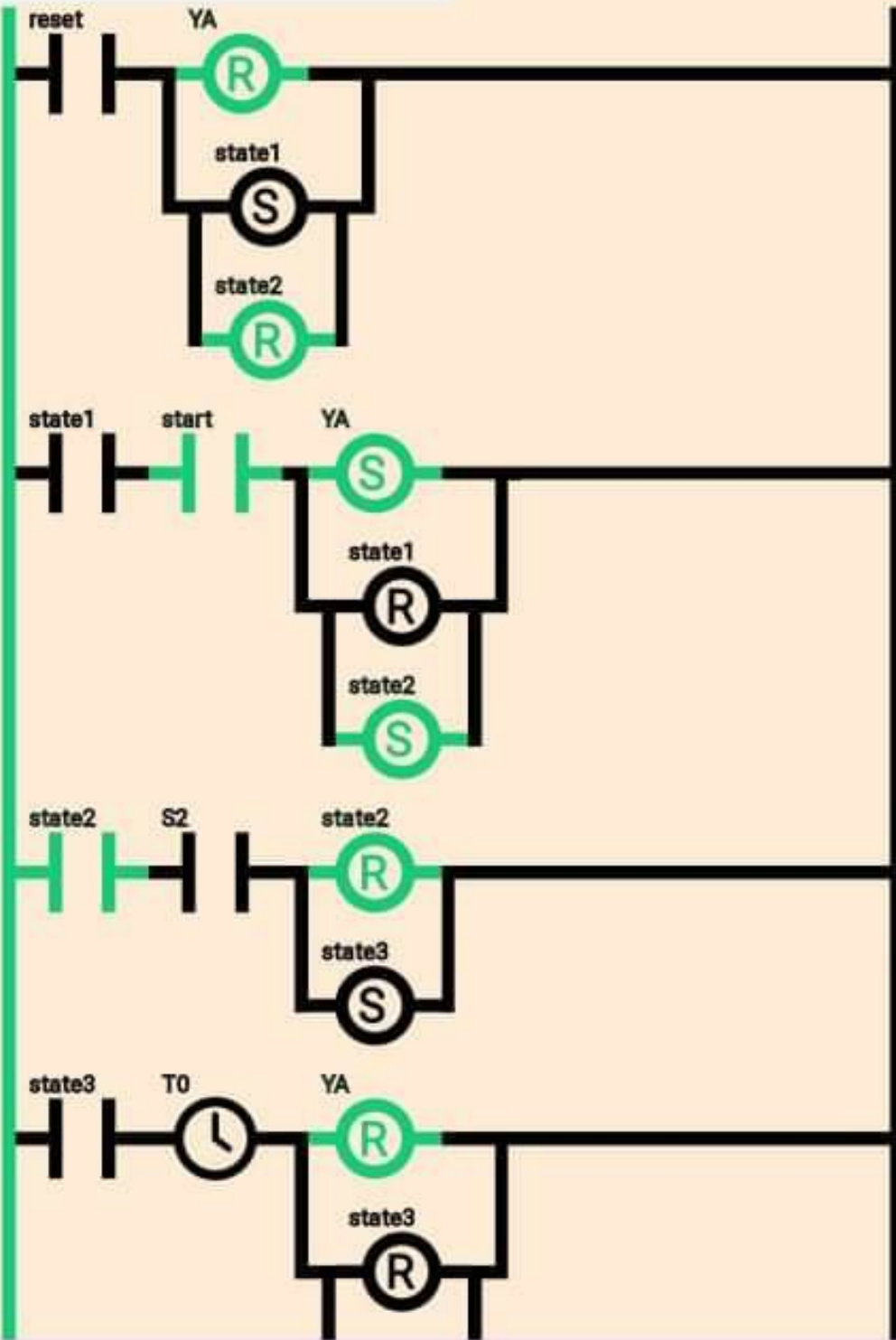



VARIABLES

DIAGRAM

Name	Type	Value
start	Bool	False
S1	Bool	True
S2	Bool	False
YA	Bool	True
state1	Bool	False
state2	Bool	True
state3	Bool	False
state4	Bool	False
reset	Bool	False
T0	Timer	▼

Add new variable

Bool



Submit





VARIABLES

DIAGRAM

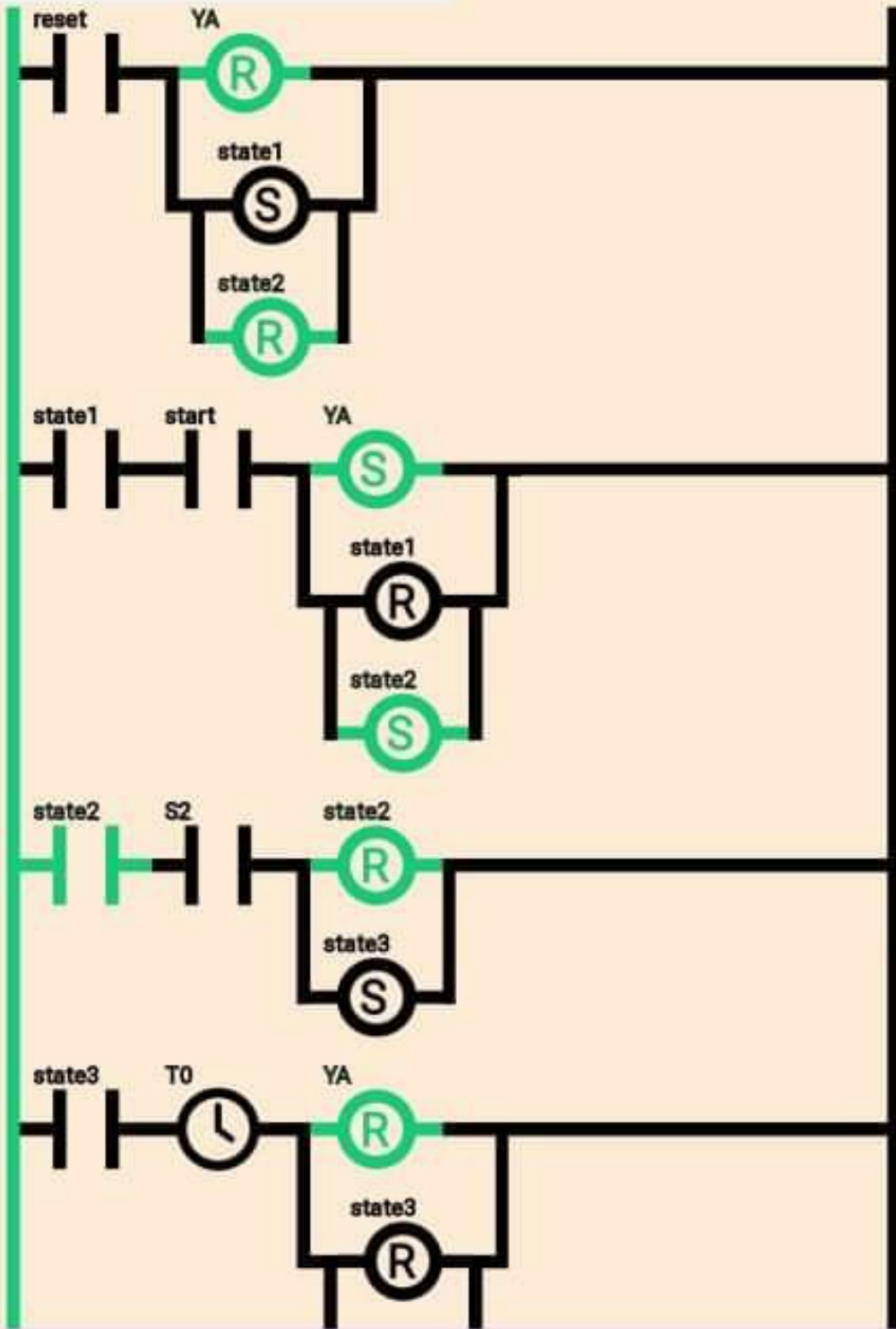



VARIABLES

DIAGRAM

Name	Type	Value
start	Bool	False
S1	Bool	True
S2	Bool	True
YA	Bool	True
state1	Bool	False
state2	Bool	False
state3	Bool	True
state4	Bool	False
reset	Bool	False
T0	Timer	^ X
PT	Time	5000
ET	Time	4092
IN	Bool	False
R	Bool	False
Q	Bool	False

Add new variable

Bool



Submit



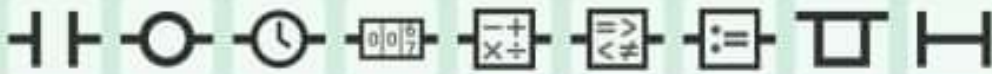

VARIABLES

DIAGRAM

