

week6mony / PLC_1 [CPU 1212C AC/DC/Rly] / Program blocks

Main [OB1]

Main Properties

General

| | | | | | | | |
|------|------|--------|---|------|----|----------|-----|
| Name | Main | Number | 1 | Type | OB | Language | LAD |
|------|------|--------|---|------|----|----------|-----|

| | |
|-----------|-----------|
| Numbering | Automatic |
|-----------|-----------|

Information

| | | | | | | | |
|-------|------------------------------|--------|--|---------|--|--------|--|
| Title | "Main Program Sweep (Cycle)" | Author | | Comment | | Family | |
|-------|------------------------------|--------|--|---------|--|--------|--|

| | | | |
|---------|-----|-----------------|--|
| Version | 0.1 | User-defined ID | |
|---------|-----|-----------------|--|

Main

| Name | Data type | Default value | Supervision | Comment |
|--------------|-----------|---------------|-------------|---------------------------------------|
| ▼ Input | | | | |
| Initial_Call | Bool | | | Initial call of this OB |
| Remanence | Bool | | | =True, if remanent data are available |
| Temp | | | | |
| Constant | | | | |

Network 1:

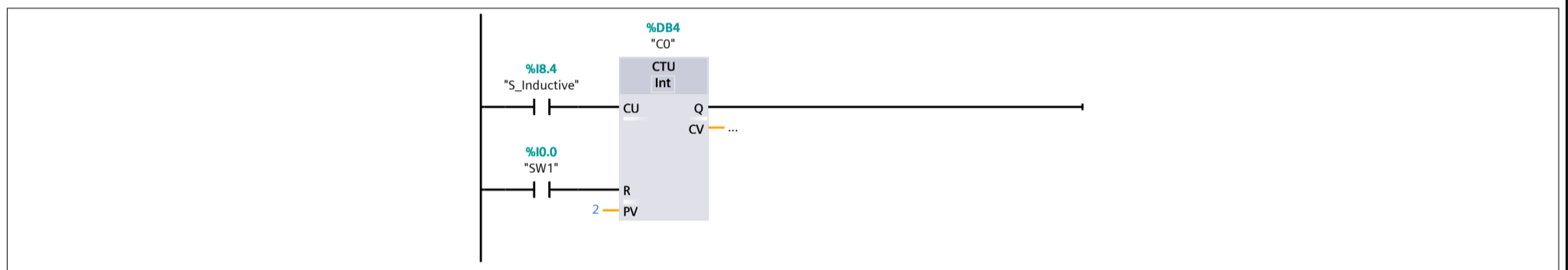

Network 2:

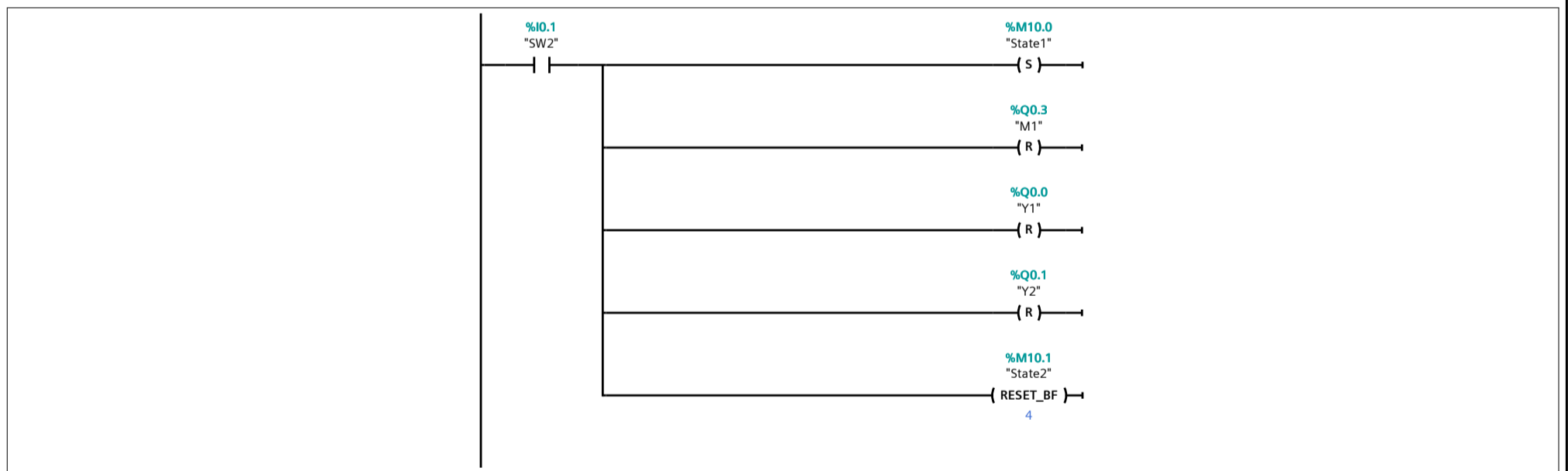

Network 3:

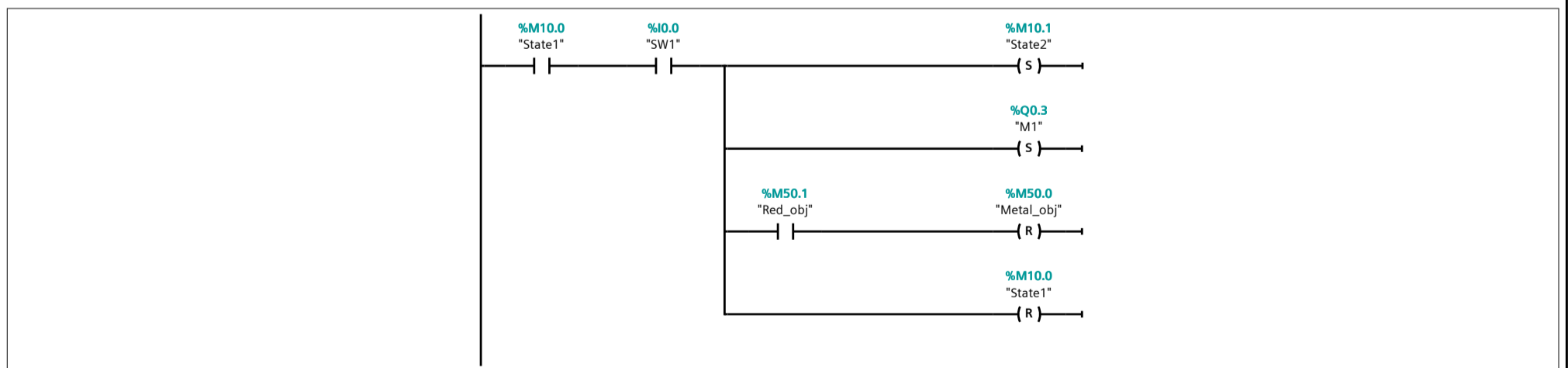

Network 4:



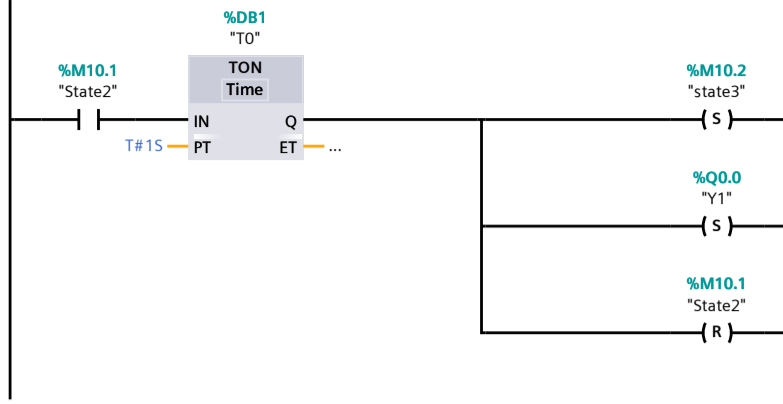

Network 5:

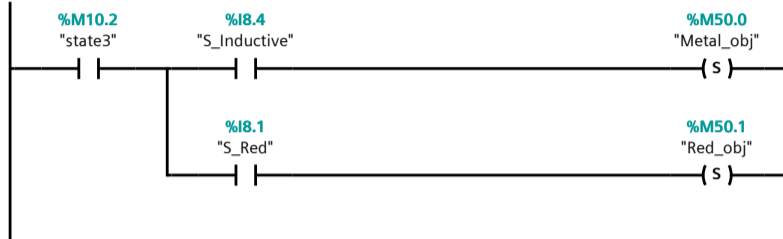

Network 6:

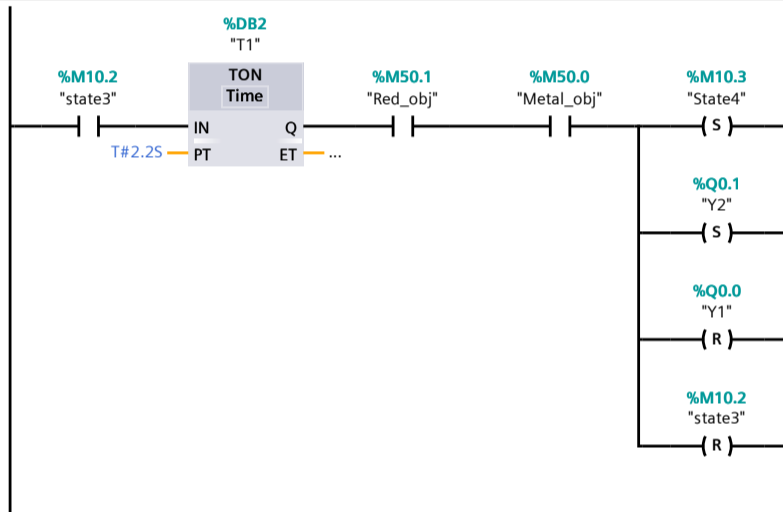

Network 7:

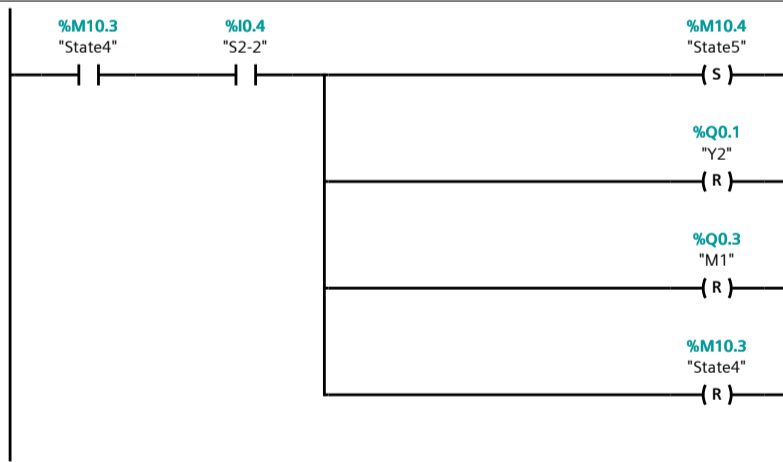

Network 8:

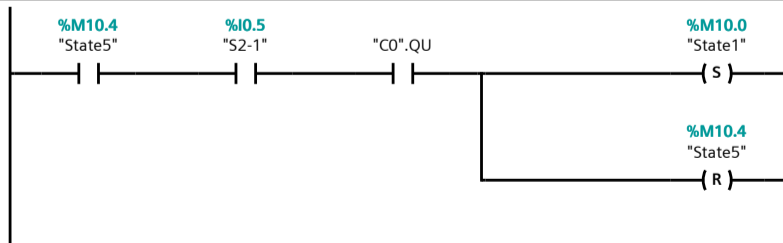

Network 9:

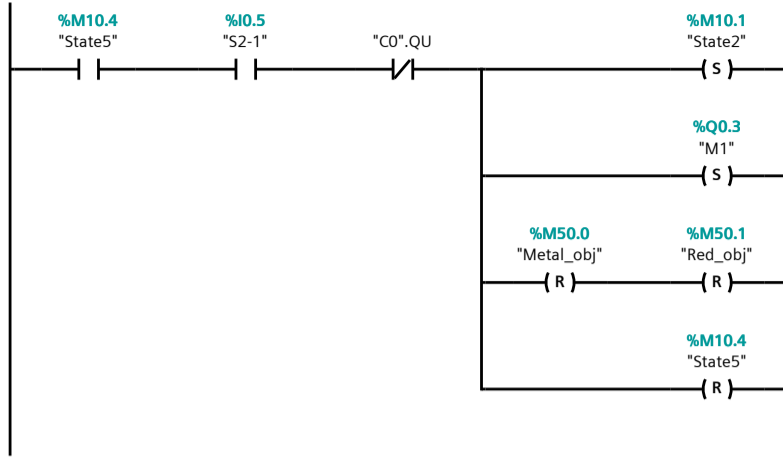

Network 10:

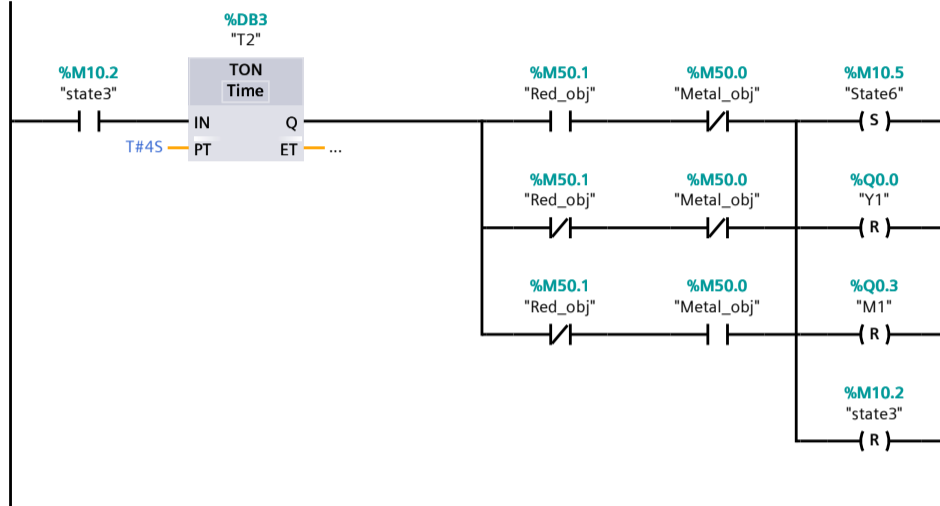

Network 11:

