

week1 / PLC_1 [CPU 1212C AC/DC/Rly] / Program blocks

Main [OB1]

Main Properties

General

Name	Main	Number	1	Type	OB	Language	LAD
Numbering	Automatic						

Information

Title	"Main Program Sweep (Cycle)"	Author		Comment		Family	
Version	0.1	User-defined ID					

Main

Name	Data type	Default value	Supervision	Comment
▼ Input				
Initial_Call	Bool			Initial call of this OB
Remanence	Bool			=True, if remanent data are available
Temp				
Constant				

Network 1:

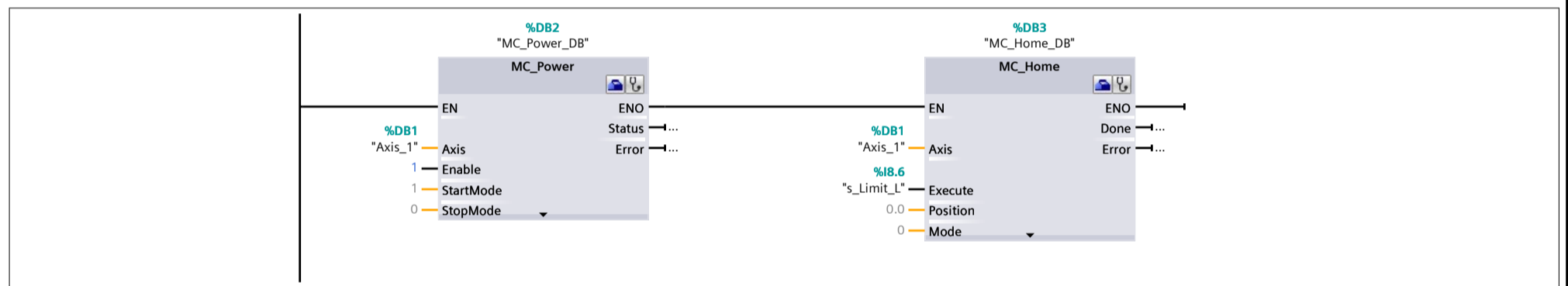

Network 2:

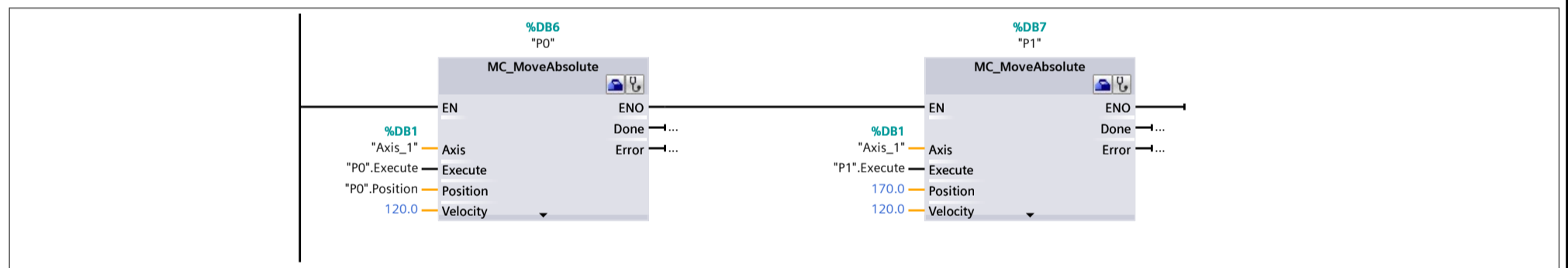

Network 3:

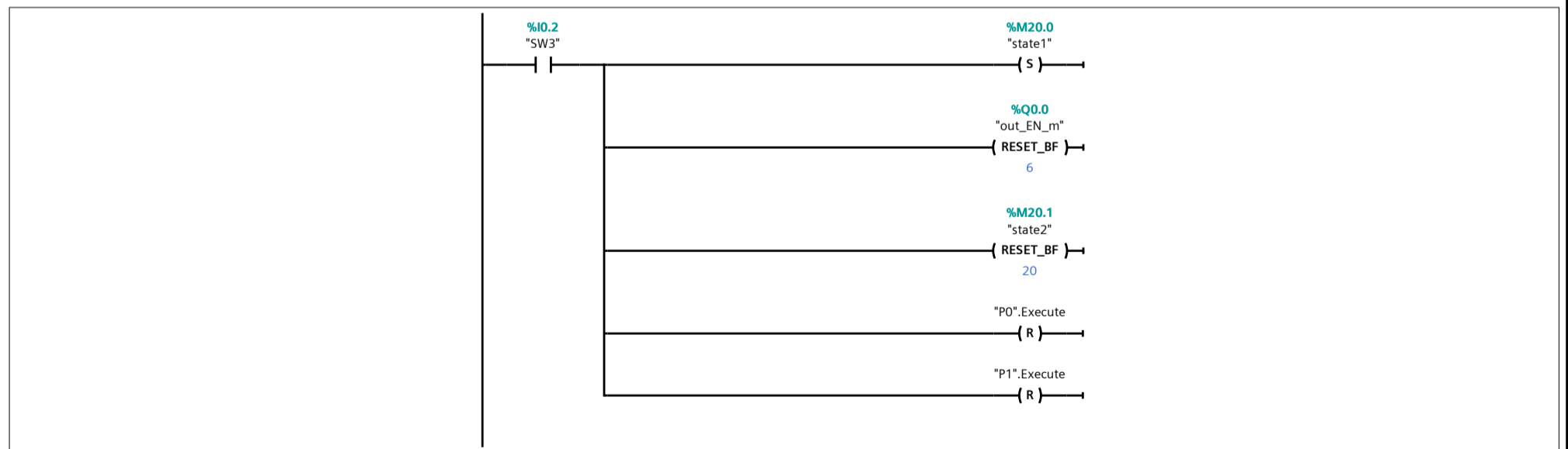

Network 4:



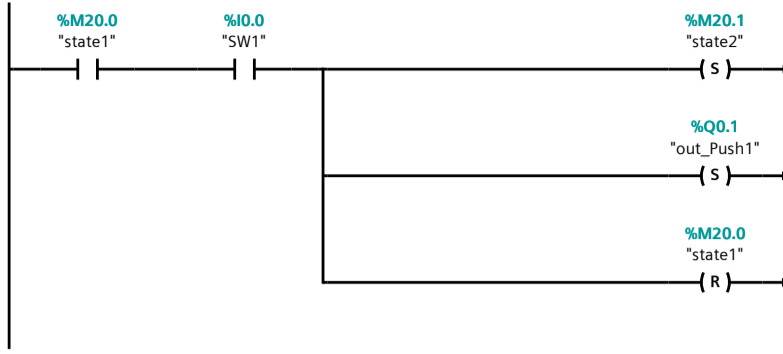

Network 5:

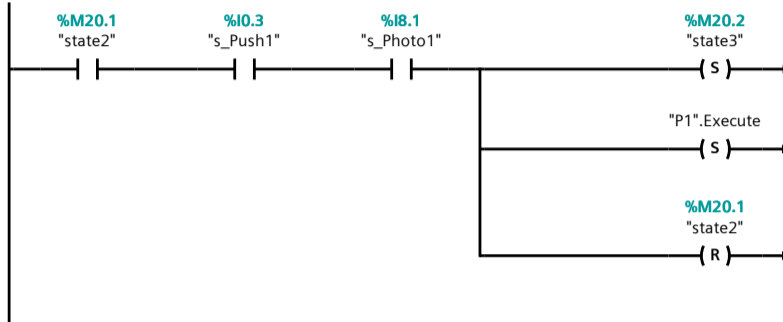

Network 6:

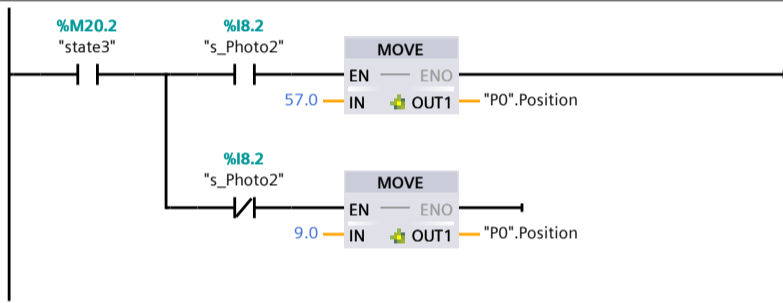

Network 7:

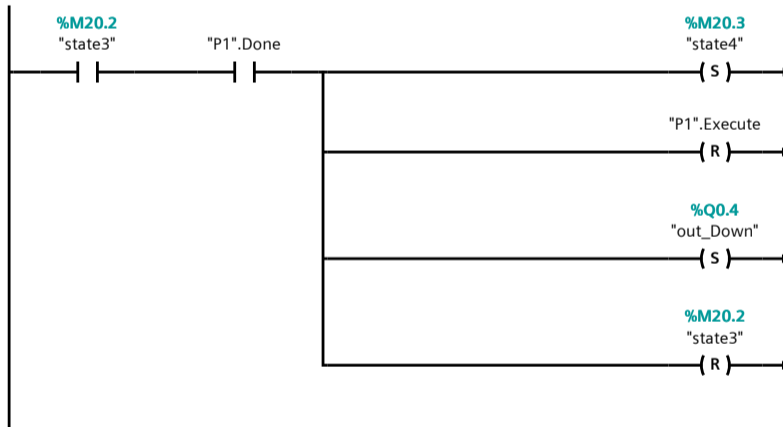

Network 8:

move up เลื่อนขึ้น

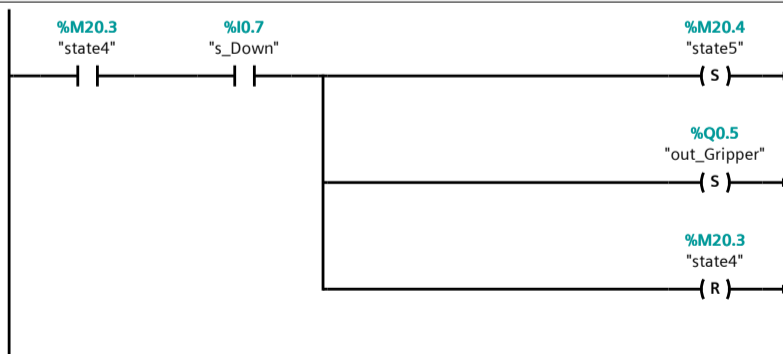

Network 9:

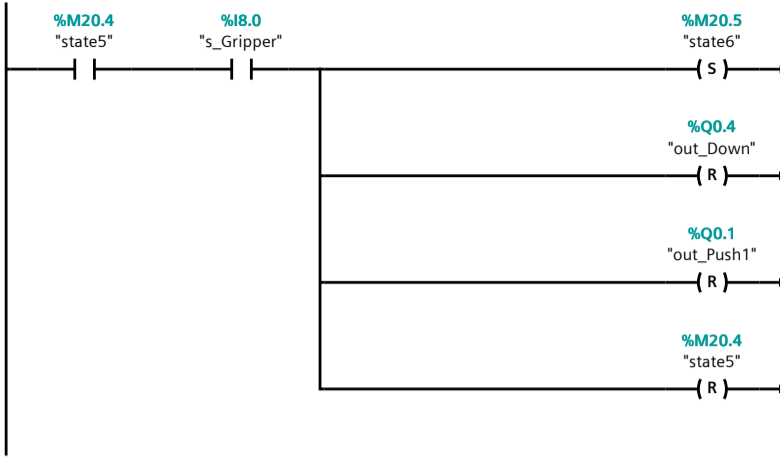

Network 10:

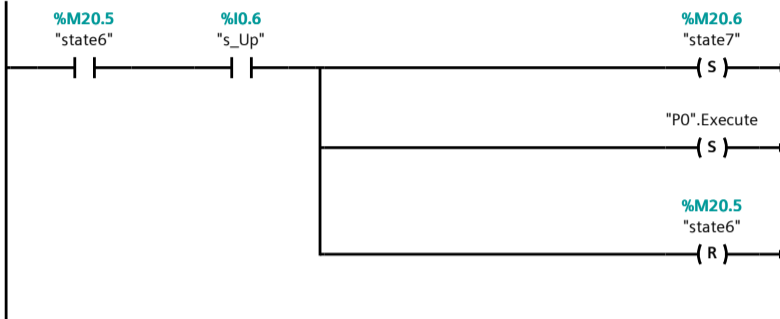

Network 11:

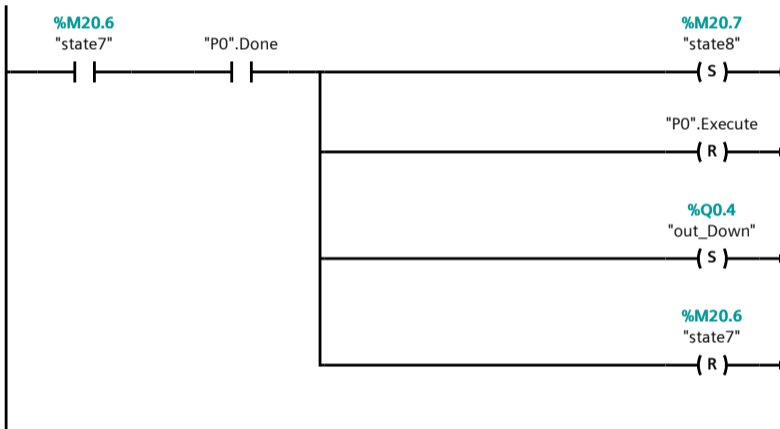

Network 12:

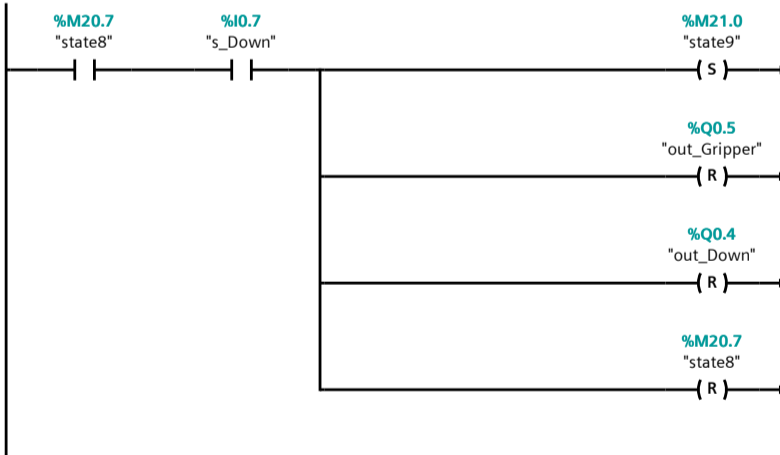

Network 13:

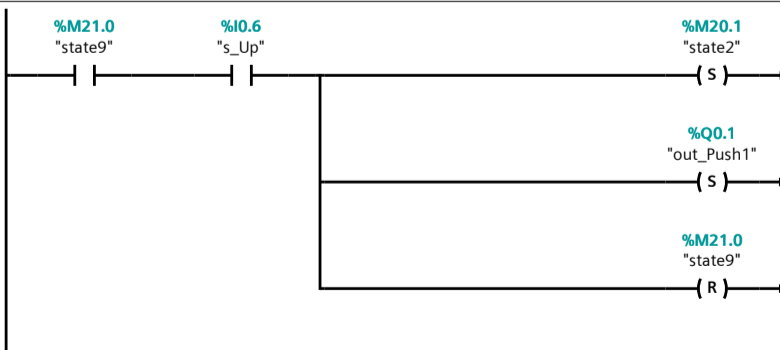

Network 14:

